

crealev

CLM 1.5

—

 **void** ^{71 mm}
└

70 mm floating height (max)
Heavy weight  (max 4 kg)

MANUAL

Let's start levitating.

Take time to carefully read the instructions in this user manual. This will allow you to install and operate the levitation module correctly and will provide you with the full enjoyment of your purchase.

This manual contains important information about safety, use, limitations, warranty and technical support.

You are strongly advised to read this user manual completely prior to using the levitation module.

By taking the levitation module in use, you accept the terms and conditions that are stated in the user manual concerning safety, use, warranty and technical support.

Keep this user manual for future reference.

71 mm floating height (max)
Heavy weight  (max 4 kg)

crealev
we make it float.

Crealev BV

Address
Klokgebouw 170
5617 AB Eindhoven
The Netherlands

Telephone number:
+31 (0)40 8519 040

Website:
www.crealev.com

General support:
crealev@crealev.com

Technical support:
crealev@crealev.com

Chamber of Commerce number :
NL 17198991 Eindhoven, The Netherlands

CONTENT

1)	GENERAL DESCRIPTION	03
2)	SAFETY AND PROTECTION	04
	a. General safety warnings	
	b. Overheating	
	c. Electromagnetic fields EMF	
	d. Power interruptions	
3)	USING THE LEVITATION UNIT	06
	a. Unpacking	
	b. Placing the base module	
	c. How to set up the levitation system	
	d. Use of the carrier ring and load	
	e. Switching the levitation system off	
4)	ROTATION	09
	a. Rotation by imbalance	
	b. Rotation motor	
5)	BUILDING VOID 71 INTO A HOUSING	09
	a. Ventilation	
	b. Hiding the unit	
6)	CLEANING AND MAINTENANCE	10
	a. Cleaning	
	b. Storage	
	c. Replacement	
	d. Environment	
7)	WARRANTY AND SERVICE	11
8)	PRODUCT SPECIFICATIONS	11
9)	DECLARATION OF CONFORMITY	12

1 GENERAL DESCRIPTION

The system is intended to levitate an object. The system can be used as a stand-alone system, but can also be built into another product or application.

The Crealev levitation system consists of 3 main parts.

1. There is an octagonal base unit with permanent magnets and electro magnets.
2. The base is supplied with a power adaptor. The adaptor is customized for VOID 71.
3. Carrier ring (carrying plateau) which contains permanent magnets.

 Never use another adaptor than the adaptor supplied by Crealev!!

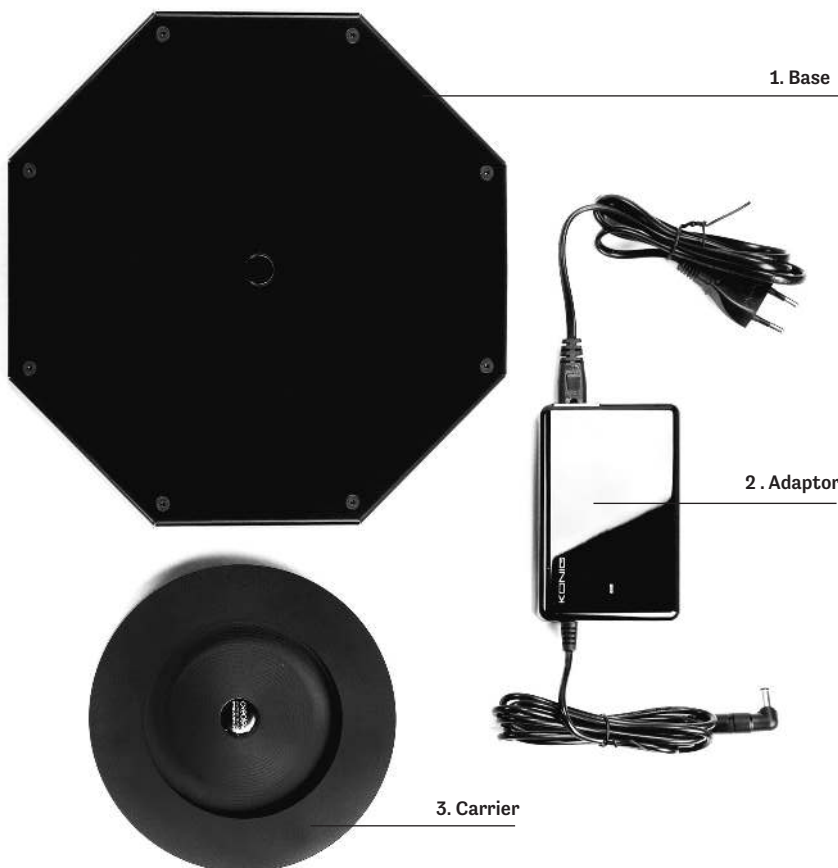

2 SAFETY AND PROTECTION

A. GENERAL WARNINGS

Please keep away from dangerous situations and refrain from creating dangerous situations like mentioned below:

Water and electricity are an extremely dangerous combination. Do not use this device in a humid environment (for example a bathroom or in the immediate vicinity of a shower, swimming pool or aquarium, etc).

Do not allow water or other liquids to enter or land on the device. The levitation module is not moisture-resistant.

Do not take the levitation module apart unless you are qualified to do so, to avoid the risk of electric shocks. Have maintenance and servicing carried out by qualified maintenance personnel. If you perform maintenance and service work yourself, the warranty will expire.

Naked flames or other heating objects such as candles or heaters must not be placed on top of or near to the levitation device.

Check that the voltage required by the appliance corresponds with the local mains voltage prior to connecting the appliance. The power adaptor is suitable for voltages from 100V to 240V. The power plug connected to the adaptor is EU two pins standard.

The mains supply works with a safety transformer, power adaptor. Replace this, if it is defective, with a new one which you can order from Crealev.

Do not damage the power cable and avoid using the cable in winded position.

Never try to remove the rubber cover at the bottom of the carrier ring.

This levitation module is not intended for use by children or persons with physical, sensory or mental disabilities, or with a lack of knowledge or experience, unless someone who is responsible for their safety supervises them or has explained to them how the levitation module should be operated.

If there are multiple levitation units, keep the magnet rings away from each other, and also do not turn the magnet rings upside down, it would be heavily attracted by the base or each other and could cause serious harm.

Situate the levitation module on a stable, level surface and ensure that there is at least 20 cm free space around the device and 40 cm above the device to prevent overheating.

Never move the levitation module during use.

Do not use the levitation module at temperatures lower than -10 degrees Celsius or higher than 35 degrees Celsius.

Ensure that ventilation openings remain open during use.

Allow the levitation module to cool off for 15 minutes before cleaning or storing.

Never use the levitation module if it is damaged or broken, or if a part is missing as indicated in the 'general description'.

The levitation unit does not have an on/off switch. If you would like to disengage the appliance from the mains supply, remove the plug from the socket. But before doing so, first remove the carrier ring from its levitation position.

Once the carrier is set-up by qualified personnel, nobody should be able to touch the floating object.

Always use a safety cover or safety guard. For example a transparent plexi glass cover.



B. OVERHEATING

The levitation module is equipped with an automatic overheating trip. If the appliance is insufficiently cooled, the device switches off automatically.

If the levitation module is overloaded or if the base has too much excitation, due to imbalance, irregular turning or other overburdening, the base can heat up and thermal protection will shut the device down.

TEMPERATURES:

The specified data apply when the module is placed on top of a table. When the module is built into a 'casing' the characteristics may differ.

Maximum operating temperature	35 [deg C]
Minimum operating temperature	-10[deg C]
Temperature rise base at no excitation	10[deg C]
Thermal shutdown case temperature	≈55[deg C]

If the safety overheating protection shuts the device down, the carrier ring will fall down on the base module. Please be aware of potential danger considering the load on the carrier ring.

If this happens, remove the cause of the overheating, remove the plug from the mains socket and allow the base module to cool off for approximately 15 minutes. Then re-insert the plug into the socket.

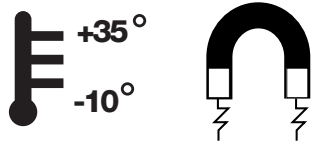

C. ELECTROMAGNETIC FIELDS

Guidelines for magnetic sensitive objects:

Due to the presence of magnets in the module and carrier, the module generates a magnetic field. This could be interfering with magnetic sensitive objects like a credit card, pacemaker or memory hardware like floppy disks and hard drives.

A distance of 10 cm (4 inch) is advised.

Technical Note:

Approximately 300 Gauss of magnetic field strength is safe for magnetic stripe devices like credit cards. The stray field at 10 cm (4 inch) distance is less than 100 [Gauss].

This levitation module complies with all the guidelines for electromagnetic fields (EMF). Providing the levitation module is used correctly and according to the instructions in this user manual, it is safe for use according to the now available scientific evidence.

D. POWER INTERRUPTION

In the event that the power is interrupted, the carrier ring will land near the levitation unit with force. This occurs with a slap, but does not have a negative effect on the operation of the levitation unit. If this occurs, 'pull' off the carrier ring from the base module, restore power, and repeat the instructions 'How to set up the levitation system' from step 3. (page 07)

Always unplug base when carrier is not in floating position to avoid overheating!

3 USING THE LEVITATION UNIT

A. UNPACKING

When you unpack the device, please keep the carrier ring away from metal objects and objects that are sensitive to magnetism, for example bank cards and memory hardware like floppy disks and hard drives.

Be careful with the carrier ring around magnetic sensitive objects or magnetic sensitive surfaces (iron). They will be attracted to each other. There is a great risk, that by trying to remove the parts, damage may occur.



Warning: never position two or more carrier rings near to each other, they attract each other with a great force, with the risk of physical injury such as trapping, bruising or worse!

B. PLACING THE BASE MODULE



The base module should be mounted horizontally on a flat and sturdy surface, preferred accuracy better than 2°.

BOTTOM OF BASE MODULE

The bottom should be open, in order to let air of the fans flow along the bottom of the unit. This is to prevent overheating of the base in case of excitation.

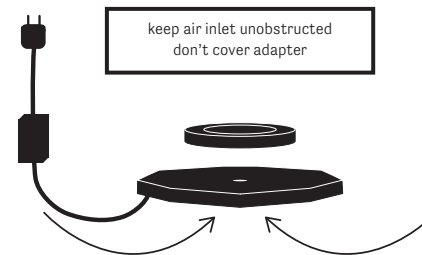

TOP OF BASE MODULE

The top can be covered with a thin sheet of any non-magnetic material, of a few millimeters thick.

The black center section on the base, the sensor, should always be left open. So any non transparent covering sheet should have an opening above the sensor.

The top could be covered by a full glass sheet or other transparent sheet material of preferably 2 mm thickness (max 3 mm).

The transparent sheet should be in direct contact with the top of the base module. The center section should always be fully transparent.

Avoid bright (sun) light on the sensor (black central part).

Module can be covered, by non magnetic materials. keep sensor eye transparent/free



Avoid bright (sun) light on the sensor (black spot)

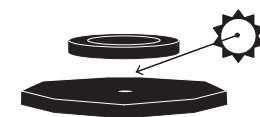

C. HOW TO SET UP THE LEVITATION SYSTEM

1. Place base module (regarding all previous mentioned requirements)
2. Connect the mains plug to the mains power supply (max 240V). (Sufficient air flow along the power adapter is necessary.)
3. In the middle of the carrier ring, there is a reflective spot. Please hold the reflective spot in the middle of the carrier ring, 8-10 cm directly above the sensor. You should now feel the repelling action of the permanent magnets in the carrier and in the levitation unit.
4. Once you feel the levitation unit coming online, the carrier ring 'locks' itself into position. The carrier ring will now be held in position by the electromagnetic field and the control system.
5. Carefully release of the carrier ring.



WARNINGS!

The carrier is held in place by an optical sensor. Therefore one must not put anything between the sensor of the base and the reflective spot of the carrier. Otherwise the carrier will fall down.

The electromagnetic field works in vertical direction. The carrier can be horizontally pushed or knocked out of balance and out of the electromagnetic field. If this happens, the carrier ring will fall down.

If the carrier ring falls down, it will land on or near base module with great force and with a slap. This situation should be avoided but this does not have a negative effect on the operation of the levitation unit.

If this occurs, please 'pull' off the carrier ring from the base module and repeat the instructions from step 3.

If a burden or load is placed on the carrier ring, make sure this can't become damaged or create a dangerous situation when the carrier ring falls down.

Only use the power supply provided by Crealev.

D. USE OF THE CARRIER RING AND LOADING

The carrier could be 'wrapped' or 'built in' other materials and objects. Please keep in mind that the reflective spot at the center bottom must be visible. So the 'casing' or load should not obstruct the center bottom of the carrier.

Always keep a matted (non glossy or reflective) circular area, with a diameter of 6 cm, around the reflective spot.

Watch out, the carrier is permanently magnetic. It attracts iron and magnetic parts. It could influence objects that are vulnerable to magnetic fields.

If the 'casing' or the load of the carrier ring contains iron or other magnetic parts; it may influence and disturb the levitation.

The heavier the load or 'casing'; the lower the levitation height.

The heavier the load; the more attention has to be paid to balancing the carrier with that load.

The heavier the load, the closer the weight should be to the carrier surface. The center of gravity should be as low as possible and centered as well possible. Avoid large or heavy weights sticking out far above the carrier surface.

Improper balancing can result in irregular rotation of the carrier and possible heating up of the base module.

Extreme irregular rotation could result in the carrier falling down.

When a load is placed on top of the carrier, the center of that load (center of gravity) should not be placed too high. If the load is placed too high the carrier and load might tip over. The numbers below give the maximum height of the center of gravity of that load.

When a load is placed on top of the carrier, the center of that load (center of gravity) should not be placed too high. If the load is placed too high the carrier and load might tip over. The numbers below give the maximum height of the center of gravity of that load.



Crealev strongly advises to keep non-authorized persons away from the levitated carrier, a distance of 1 meter is recommended. Touching the levitated carrier or blocking of the sensor eye on the module may cause the carrier to fall down and can possibly cause injury or damage.



Crealev recommends the placement of a protective casing like for example a transparent tube around the levitation system (crosssection transparent tube 45 cm).

HEIGHT LIMITATIONS OF THE LOAD (PRODUCT):

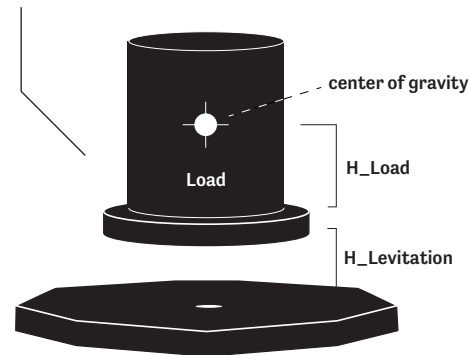

Maximum load location on top of carrier ring:

Load = 0 kg	H_load = -	H_levitation = 71 mm
Load = 1 kg	H_load = 190 mm	H_levitation = 52 mm
Load = 2 kg	H_load = 130 mm	H_levitation = 43 mm
Load = 3 kg	H_load = 105 mm	H_levitation = 35 mm
Load = 4 kg	H_load = 90 mm	H_levitation = 28 mm

E. SWITCHING THE LEVITATION SYSTEM OFF

If the carrier ring is in the levitating (floating) position, carefully remove the carrier ring with its load from the position and place it away from any metal or magnetic objects.

Pull the power plug out of the mains socket.

Allow the levitation module to cool off for 15 minutes before cleaning or storing.

When the levitation device is stored, place the carrier ring on the base module with a 5 cm foam layer in between.

4 ROTATION

Rotation can be achieved in two ways.

A. ROTATION BY IMBALANCE

The object you want to levitate is placed slightly off-center on the floating carrier. Then a little spin will let it turn indefinitely. You have to find the exact right spot for the object. Otherwise the unit will speed up and spin out of control. Or the object will decrease in speed and stand still. Big plus: low cost. However, this doesn't work for all objects. It works best with objects that have simple forms, are very symmetrical, and homogenous.

B. ROTATION MOTOR

The base unit will be placed on a rotation motor. Extra magnets are added on 2 or 4 quadrants of the floating carrier, giving it a preference position in reference to the base. Once the motor turns, the base turns and the carrier turns. The big plus: controlled rotation of a set amount of RPM. For this option extra costs are involved. These adaptations have to be done at CREALEV. Please contact us for more information.

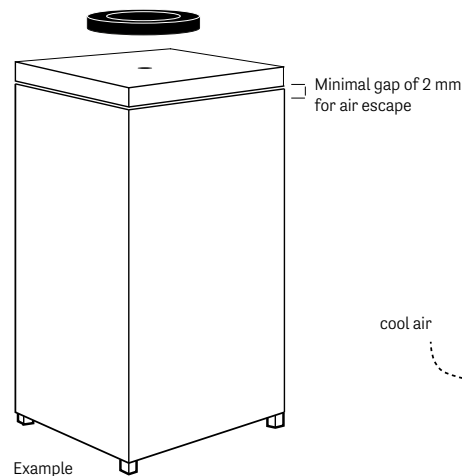

5 BUILDING VOID 71 INTO A HOUSING

B. VENTILATION

The VOID 71 has air-intakes and exhausts at the bottom (rectangular holes are exhausts, the round ones are intakes). This means the hot and cool air have to be separated and that the airflow inside the housing is enforced by adding an extra fan.

THE IMPORTANT THINGS ARE:

- Try not to stretch the limits of the module in terms of a too heavy object, or too high. (this will create heat.)
- Make sure there is active ventilation (a fan).
- Make sure the airflow is bottom to top
- Make sure the hot air and cool air don't mix.

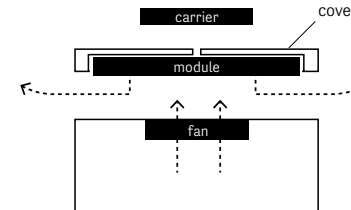
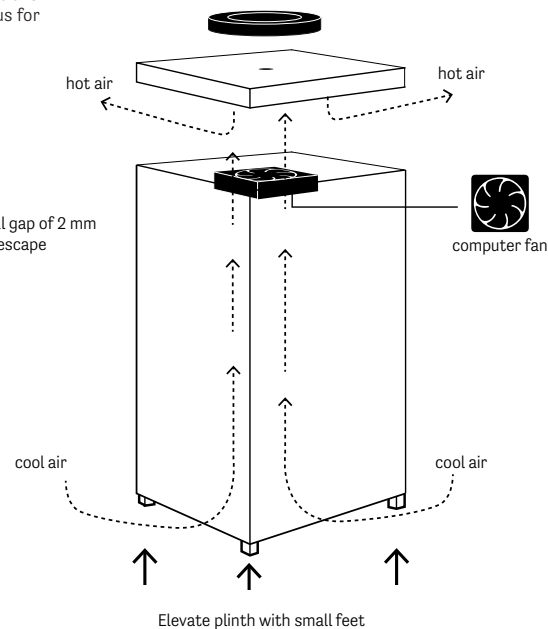

A. HIDING THE UNIT

The base can be covered with anything that isn't magnetic. So wood or aluminum is possible. However, there needs to be a hole in the center of the unit for the optical sensor. Our systems use an optical sensor on the base and a reflector on the floating carrier. This path must be unobstructed for the levitation unit to function.

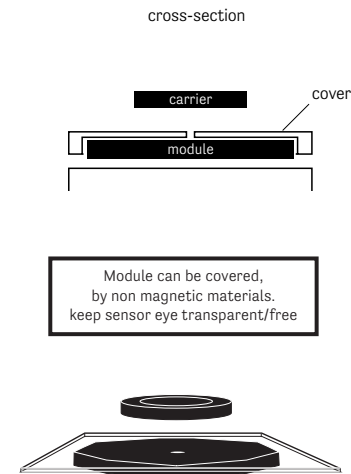

6 CLEANING AND MAINTENANCE

A. CLEANING

Always remove the plug from the mains socket and allow the levitation module to cool for approximately 15 minutes before you clean it.

Never use abrasive sponges, abrasive cleaning agents or aggressive solvents such as white spirit or acetone for cleaning the levitation module.

Remove dust from the appliance regularly, especially from the optical sensor in the center, using a dry cloth, because dust can have a negative effect on the operation of the levitation technology.

Clean the exterior of the levitation module with a clean damp cloth.

Do not allow any water or other liquids to enter or land on the base module.

B. STORAGE

Please store the levitation module, preferably in the packaging or protective wrappings.

Please store the levitation module in a dry safe place without extreme temperatures.

When the levitation device is stored, place the carrier ring on the base module with a 2 cm foam layer in between.

C. REPLACEMENTS

In case of malfunction or defects the levitation module can be returned to Crealev for possible adjustment or repair.

D. ENVIRONMENT

Do not dispose of this device at the end of its life-cycle with the rest of the normal household refuse.

Preferably deposit it at one of the government indicated collection points so that it can be recycled. In doing so, you will be contributing to a cleaner living environment.

7 WARRANTY AND SERVICE

If you require service, information or if you have a problem, please visit www.crealev.com. If your country has a distributor, please approach your distributor first.

There is a 1-year international warranty on all parts. Shipment costs are for the buyer. Repair and replacement costs within period of warranty are on behalf of Crealev BV. The warranty expires if the device has been altered by others.

Hereby any buyers, resellers or users located in the US or Canada take full responsibility for any irregularities/damage or negative effects that may occur while using the Crealev Levitation Module.

For any other service, questions or information, please contact us: crealev@crealev.com.

8 PRODUCT SPECIFICATIONS

- Rated input voltage 110-240V
- Rated frequency 50-60Hz
- Rated input 120 Watt
- Rated output 120 Watt / 19 V / 6 Amp
- Class III (only suitable for low voltage 19V)
- Classification none
- Water penetration IP x 0
- Conditions for use temp: from -10°C to +35°C
- Relative humidity: from 30% to 90%
- Storing conditions temp: from -20°C to +50°C (no condensation)

You must take measures to prevent electromagnetic faults or other faults between this device and other appliances.

9 DECLARATION OF CONFORMITY

We,

Crealev BV
Klokgebouw 177
5617 AB EINDHOVEN
Netherlands

declare under our sole responsibility that the product as originally delivered,

Name: Levitation module
Type: VOID 71 (CLM-1.5)

Function: The VOID 71 is a universal module that is able to levitate objects all kinds of objects. The modules consist of a base above which a magnetic disc floats. This magnetic disc serves as floatation plateau for objects. As well the base as the floatation disc can be integrated in products. The disc will be integrated in the floating part of that product. The base contains electronic elements for stabilization of the levitation system. The disc does not contain any electronics, it contains only passive permanent magnets.

The module complies with the essential requirements of the following European Directives, and carries the CE marking accordingly:

Low voltage directive: EN 2006/95/EC
EMC directive: EN 2004/108/EC
RoHS directive: EN 2002/95/EC

and conforms with the following harmonized European standards:

EN 60204-1: 2006 Electrical safety, part 1
EN 61000-6-1: 2007 EMC, Immunity, part 6-1
EN 61000-6-3: 2007 EMC, Emission, part 6-3
EN 14121-1 Risk analysis
NEN 5509 Design for user manuals

Eindhoven, The Netherlands
Date: 20-3-2011

Ger Jansen
Director Crealev BV
Signature:

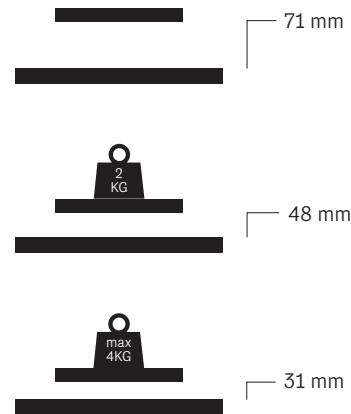
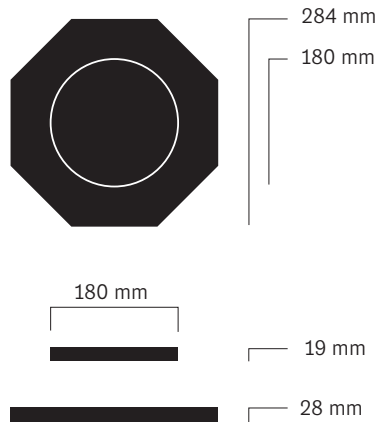
Tag or mail us your creation;
We would love to see your project!

#crealev

#wemakeitfloat

crealev we make it float.

join us on [f](#) get inspired on [i](#) watch us on [v](#)